

SCHÜCO

PVC-U sliding system

Schüco Living move

PRODUCT NEWS



The new sliding window and door system from the

Schüco Living series

combines optimum weathertightness with the highest requirements in terms of thermal insulation and comfort.

With Schüco Living move, the diverse requirements of architects, housing development associations, investors and private clients can be fulfilled, especially when used as a window system with sliding function, which accommodates space-saving room concepts. The sliding system offers individual solutions of the highest standard in terms of comfort, energy efficiency, security and design. Above all, Schüco Living move impresses with its exceptional weathertightness values which make the series ideal for use as a sliding door or window in multi-storey buildings. A choice of two gasket concepts (rebate or centre gasket) ensures flexibility in the design, which takes into account individual requirements for thermal insulation, sound reduction and weathertightness.

The series complements the Schüco PVC-U sliding portfolio and offers alternative design options to other system solutions – for both commercial and private projects.

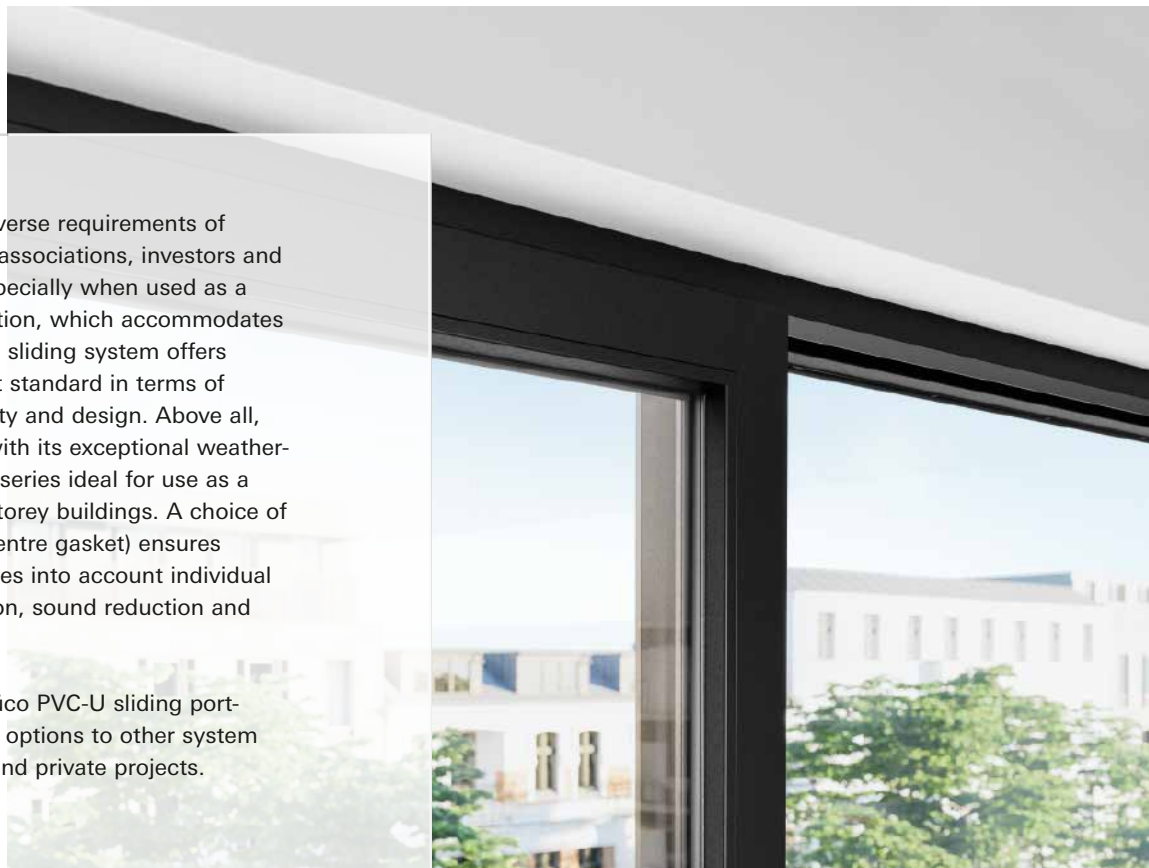

Product highlights

- **For the construction of sliding windows and doors** and as an alternative to tilt/slide and lift-and-slide doors
- The structure is characterised by a **high level of weathertightness** and **very good thermal insulation**
- **Durable, weld-on gaskets** for the best thermal insulation, sound reduction and weather protection
- Burglar resistance up to **resistance class RC2**
- **Maximum degree of design freedom** with metallic and single colours or woodgrain finishes from the Schüco UnlimitedFinish range and cover caps from the Schüco TopAlu series
- **Suitable fittings and handles** available to match the system
- **Smooth and easy operation** with the compatible range of handles → handle position on the vent can be freely selected

- 1 **Centre gasket** for optional use with increased requirements
- 2 **Use in newbuilds and renovations** with glazing up to 52 mm thick
- 3 **Schüco Livng glazing rebate geometry**
- 4 **Secure crack ventilation with an opening width of 6 mm** makes ventilation easier and prevents the vent from unintentionally sliding open

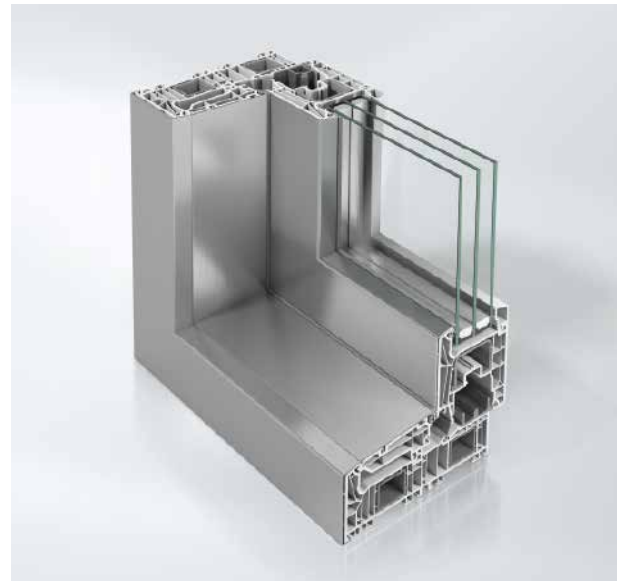
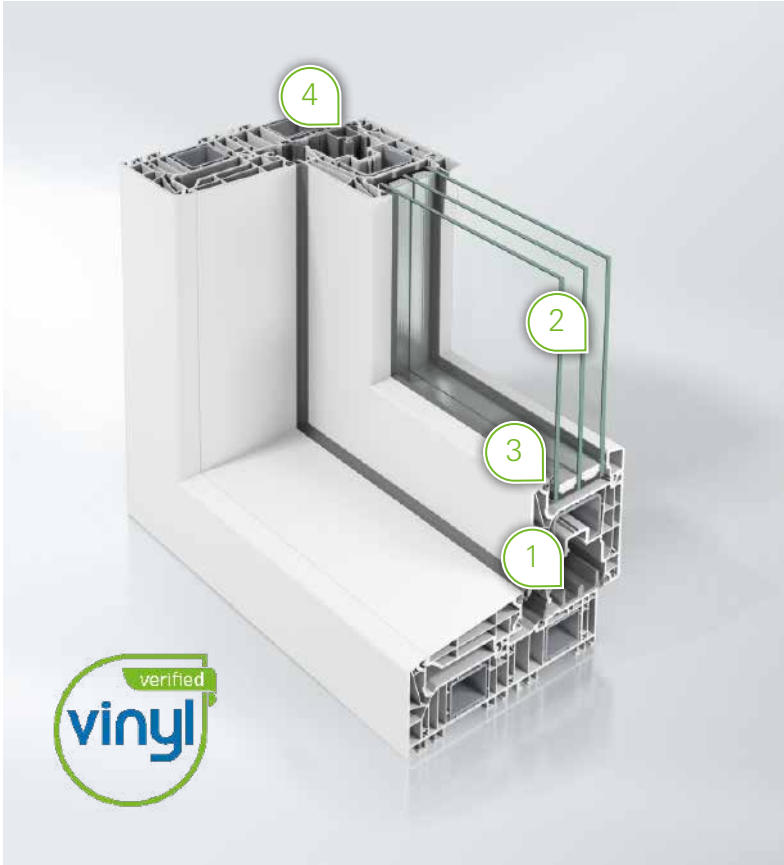

Schüco Livng move TopAlu offers even more design options for implementation or integration in aluminium façades

Opening types

Type 01 LS

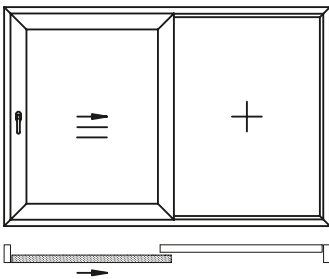

Type 01 RS

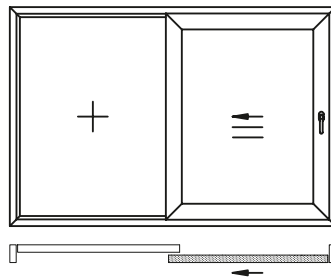

- 1 **Access vent**
- 2 **Secondary vent**

Type 06 LS

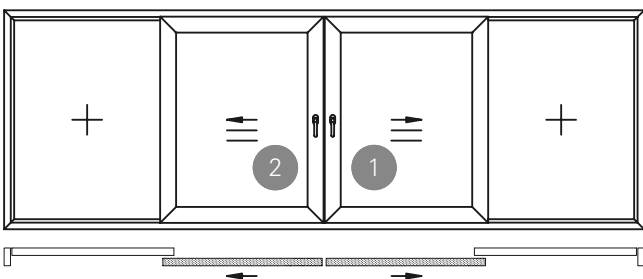

Type 06 RS

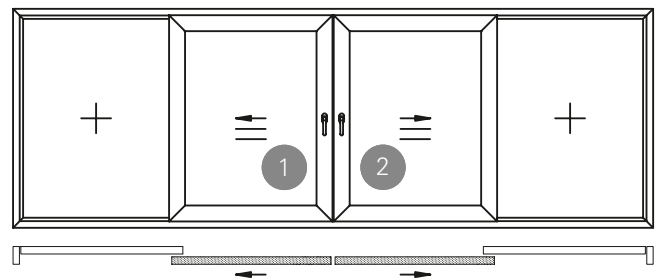

Fabrication benefits

- Designed for economical and partially automated fabrication as well as simple and cost-effective installation
- Schüco **Living** is the basis for the vent profile which ensures the use of identical parts in the glazing area
- Fabrication of vent frame in serial production
- Use of triple glazing possible for glass thicknesses of up to 52 mm
- The gasket concept comprises two gasket levels as standard and there is the option to add a third, centre gasket
- Large volume reinforcements for various structural requirements are available
- Design with Schüco TopAlu with the usual cover caps is possible
- Sophisticated sliding fitting which is simple and quick to install
- Excellent accommodation of tolerances in the centre joint area due to possible adjustment of +/- 5 mm

System details

Technical data	Schüco Living move
Basic depth of outer frame / frame trim	159 mm
Basic depth of vent frame	82 mm
Possible glazing thickness	16 – 52 mm
Maximum vent weight	250 kg
Maximum unit dimensions (width x height) [woodgrain version]	4422 x 2500 mm [4422 x 2400 mm]
Test values	
Thermal insulation in accordance with DIN EN 12412-2	U_i to 1.1 W/(m ² K)
Sound reduction in accordance with DIN EN ISO 140-3	Rw,P being tested
Burglar resistance in accordance with DIN EN 1627	RC 2
Air permeability in accordance with DIN EN 12207	Class 4
Watertightness in accordance with DIN EN 12208	Class 8A
Resistance to wind load in accordance with DIN EN 12210	Being tested
Mechanical loading in accordance with DIN EN 13115	Class 4
Operating forces in accordance with DIN EN 13115	Class 1

The "Schüco" logo and other logos are protected in Germany and various international markets. Detailed information is available upon request.

P4183/07_23/Printed in Germany
We reserve the right to make changes and to correct errors.
Products may differ from illustrations.



Schüco Polymer Technologies KG

www.schueco.com

Follow us:

